

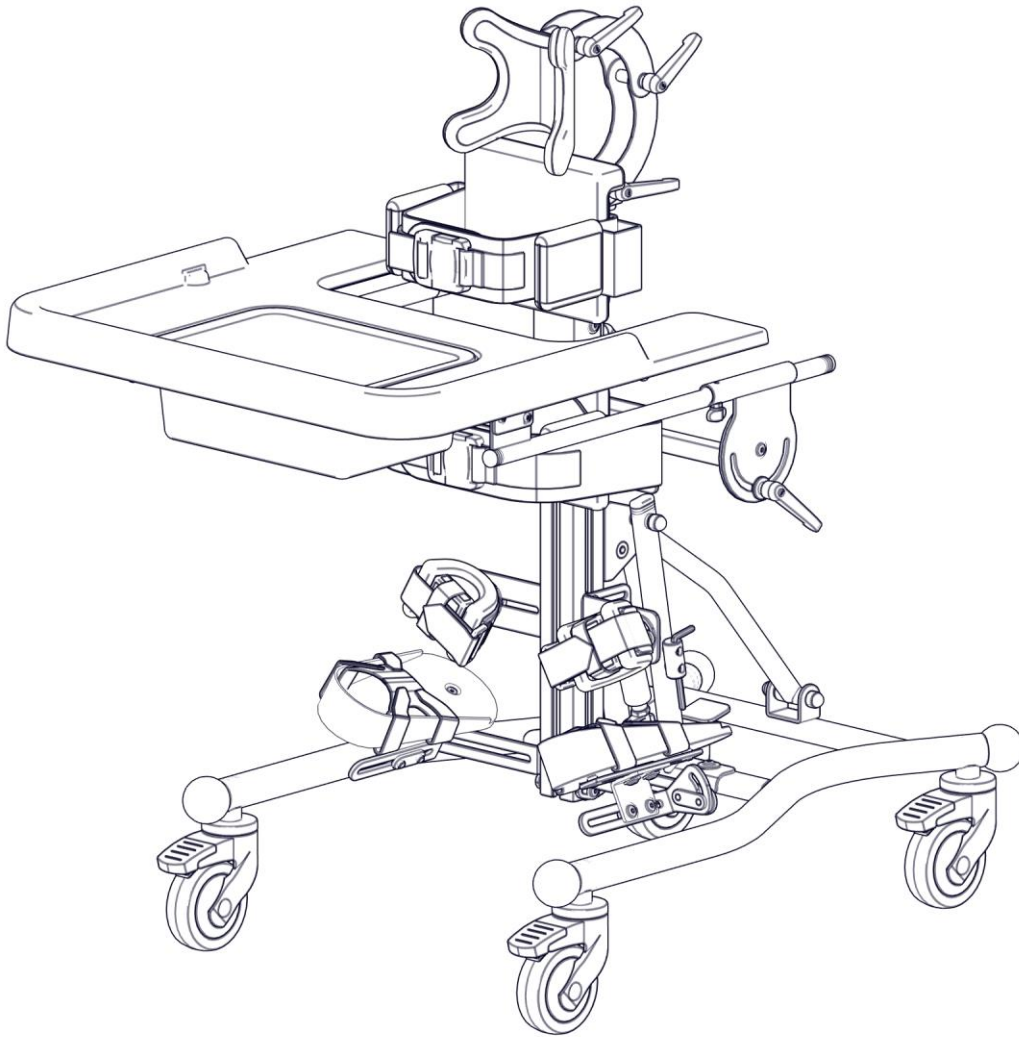

USER MANUAL

LORI Stander



edition 5 – 2022.02.17



CAUTION! THE MANUFACTURER IS ONLY RESPONSIBLE FOR THE PRODUCT PURCHASED DIRECTLY FROM THE LOCAL REPRESENTATIVE OF LIW CARE TECHNOLOGY OR IN A SPECIALISED MEDICAL STORE REPRESENTING LIW CARE TECHNOLOGY WITHIN THE TERRITORY OF POLAND.



CAUTION! THIS PRODUCT CAN ONLY BE USED INDOORS.



CAUTION! THERE MAY BE A RISK OF TRAPPING AND/OR SQUEEZING PARTS OF THE BODY OF THE USER / ACCOMPANYING PERSON IN THE OPENINGS / SLOTS BETWEEN THE ELEMENTS WHEN USING THE PRODUCT, AS WELL AS WHEN ASSEMBLING AND ADJUSTING THE MECHANISMS. THESE PROCEDURES SHOULD BE PERFORMED WITH PARTICULAR CAUTION. WHEN ALL THE ADJUSTMENTS HAVE BEEN PERFORMED, IT IS CRUCIAL TO STABILISE THE POSITION BY PROPERLY TURNING THE NUTS / SCREWS.



CAUTION! IF POSSIBLE, THE PACKAGING OF THE PRODUCT SHOULD BE MAINTAINED IN CASE THE PRODUCT NEEDS TO BE TRANSPORTED AGAIN IN THE EVENT OF WARRANTY REPAIR.



CAUTION! THE CHILD MUST NOT USE THE DEVICE WITHOUT SUPERVISION.



CAUTION! THE MAXIMUM LOAD OF THE STANDER MUST NOT BE EXCEEDED.



CAUTION! DO NOT USE THE STANDER IF THE PRODUCT HAS DEFECTIVE, DAMAGED OR MISSING COMPONENTS.



CAUTION! ADJUSTMENT AND REGULATION OF THE DEVICE TO MEET THE REQUIREMENTS OF AN INDIVIDUAL PATIENT MUST BE PERFORMED BY A PHYSIOTHERAPY SPECIALIST OR A TRAINED PERSON.



CAUTION! IT IS NECESSARY TO CAREFULLY READ THE USER MANUAL BEFORE USING THE DEVICE.

1. Introduction	4
1.1. General safety conditions	4
2. Identification of symbols.....	4
3. Compliance with requirements concerning medical devices.....	5
4. Indications for using the device	5
5. Technical data	6
6. LORI Stander – design	7
7. Detailed description of the construction and adjustments of the LORI Stander	8
7.1. Assembly of the stander	8
7.1.1. Disassembly of the frame	8
7.1.2. Installation of the column - Figures 4 and 5	9
7.2. Wheels – Figure 6	10
7.3. Main Hip support – Figure 7	10
7.4. Lateral support (hip or chest support) – Figure 8.....	11
7.5. Adjustment of chest and hip supports – Figure 9.....	12
7.6. Chest/hip belt/harness – Figure 10	12
7.7. Knee pads – Figure 11.....	13
7.8. Foot platforms	13
7.8.1. Adjustment of height and tilt of foot platforms - Figure 12	13
7.8.2. Adjusting the spacing and inclination of the foot platforms	14
7.8.3. Adjustment (front-back) and rotation of the foot platform - Figure 14	15
7.8.4. Installation of platforms in forward and reverse vertical position	15
7.9. Vertical position – Figure 16	16
7.10. Blocking the release button.....	17
8. Accessories.....	18
8.1. Tray.....	18
8.1.1. Adjustment of the tray tilt angle – Figure 18.....	18
8.2. Headrest for supine position – Figures 20 and 21	19
8.3. Corrective hip strap - Figures 22 and 23	20
8.4. Shoulder protectors – Figure 24	21
8.5. Fastened SideUP chest supports (flip away laterals) – Figure 25	21
8.6. Installation and adjustment of the vest.....	22
8.7. 3D Pelvic&Hip support and positioning system.....	22
8.7.1. Adjustment of the pelvic pelottes of the back support	24
8.8. Installation and adjustment of the head support for the front stabilisation.....	24
8.9. Installation of the leg abduction adapters.....	26
8.9.1. Knee pads of leg abduction adapters.	27
8.9.2. Feet platforms for leg abduction adapters.....	27
8.9.3. Adjustment of the height of feet platforms for leg abduction adapters.	28
8.9.4. Adjustment of the tilt of feet platforms for leg abduction adapters.....	28
8.9.5. Adjustment (front-back) of the feet platform for leg abduction adapters.	29
8.9.6. Installation of the knee pad in front and supine verticalization in leg abduction adapters.	29
9. Cleaning and maintenance	30
9.1. Recommendations for cleaning and maintenance	30
The sponge-foam insert:.....	31
• Should be vacuumed mechanically or cleaned using a soft-bristled brush.	31
• Can be washed with a damp cloth and a mild detergent, then dried thoroughly at room temperature.	31
9.2. Disinfection.....	31
10. Nameplate	31
11. Warranty/Service	32

1. Introduction

The LORI **Stander** developed by LIW Care Technology Sp. z o.o. has been designed and patented to ensure an entirely new quality in rehabilitation.

We have used our best efforts to make sure that the LORI Stander is as easy to use as possible. It is necessary to read the user manual carefully prior to using the product. Following all instructions and recommendations included in this user manual will allow you to avoid any situations which could damage the device, and you will also ensure the complete safety and comfort of use throughout the whole period of using the product.

You will be able to fully use all the advantages offered by the product only when it is properly adjusted to the parameters of the patient's body and the specific requirements of the patient.

1.1. General safety conditions

The biggest concern of LIW Care Technology Sp. z o.o. is to ensure safety for the patients using our devices. In order to provide complete safety of the persons using the device, it is essential to strictly follow the recommendations stated below:

1. Before undertaking any attempts to use the device, please read the user manual thoroughly and in case of any doubts, do not hesitate to contact the seller or the manufacturer.
2. Please make sure that all the information, recommendations and cautions included in these chapters are fully comprehensible.

The user manuals attached to devices manufactured by LIW Care Technology Sp. z o.o. include paragraphs marked with the word CAUTION, intended to emphasise the content of the given paragraph. The significance of the above-mentioned symbol is as follows:



CAUTION! THIS SYMBOL IS USED TO STRENGTHEN THE FOCUS OF THE READER ON THE CONTENT MARKED WITH THIS SYMBOL. FAILURE TO COMPLY WITH THE CONTENT UNDER THIS SYMBOL MAY ENDANGER THE LIFE OR HEALTH OF THE USER.

2. Identification of symbols



Manufacturer name



Production date

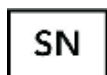

Serial number



Permitted user weight



Avoid contact with water



Follow the user manual



The arrow indicates the discussed element



Arrows indicating the direction of movement



Conformity marking according to the Regulation 2017/745 of the European Parliament and of the Council (EU) dated from April 5th, 2017 on medical devices, Annex V.



Medical device

3. Compliance with requirements concerning medical devices

Hereby we confirm that the LORI Stander meets requirements of the Regulation of the European Parliament and of the Council (EU) 2017/745 dated from April 5th, 2017 on medical devices.

LORI Stander in accordance with Annex VIII of the Regulation of the European Parliament and of the Council (EU) 2017/745 dated from April 5th, 2017 on medical devices is a non-invasive, active class I medical device according to the rule 1.

Conformity declaration of the device can be obtained in the Sales Department of the manufacturer.



CAUTION! In case of any modification of the device, the use of non-original spare parts or use with products of another manufacturer, the CE marking must be removed.

4. Indications for using the device

LORI Stander can be used in persons with posture defects and muscle dysfunction. It is the perfect solution for children suffering from cerebral palsy, muscular dystrophy, in various types of paralyses, tetraplegias and paraplegias, as well as for children with posture disorders. This device may also be used for therapeutic and prophylactic reasons, as it can prevent the inevitable consequences of paediatric diseases (incorrect posture and related disorders).

Obtaining a vertical position allows to improve the functioning of patient's systems and organs, in particular:

- cardiovascular system,
- respiratory system,
- digestive system,
- skeletal system.

Using the device during the rehabilitation process of the patient increases the chances of recovery.

5. Technical data

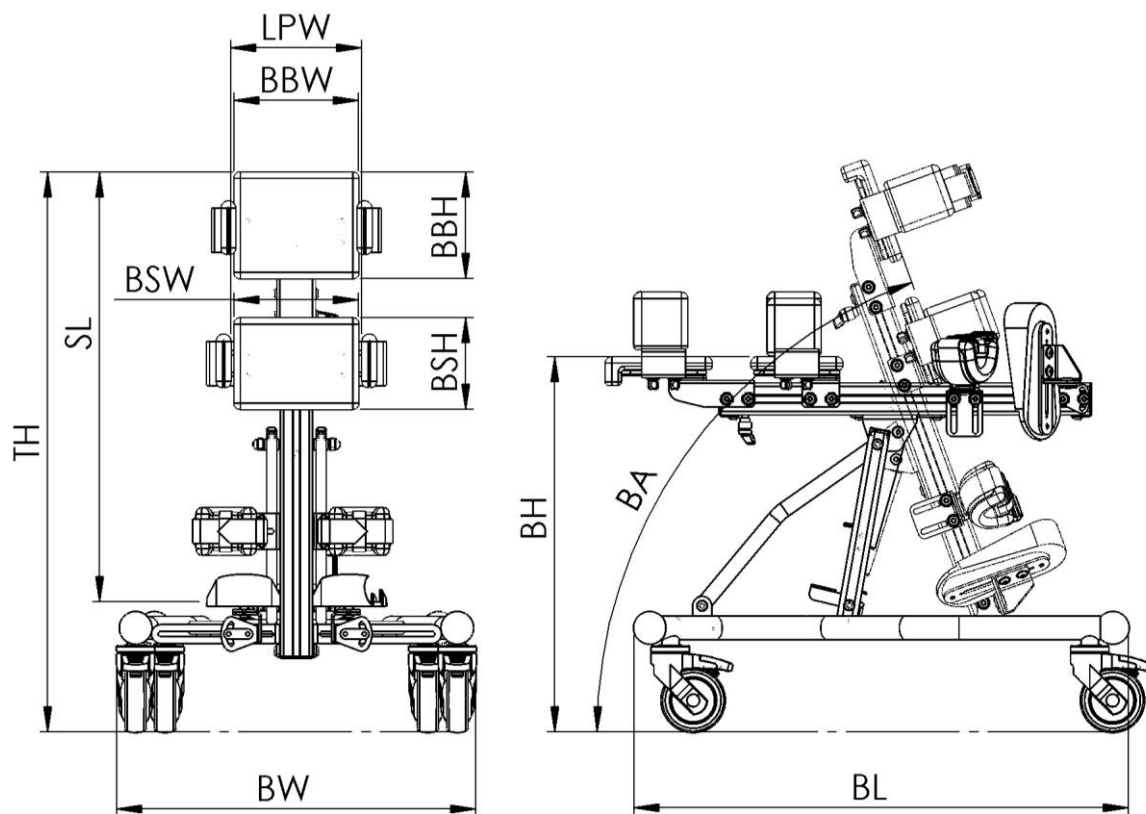

Figure 1

No.	Dimensions	Symbol	Size [cm]	
			1	2
			Baby	Junior
1	Base width	BW	63	63
2	Base length	BL	78	78
3	Total height (without headrest)	TH	94	120
4	Platform height	BH	60	75
5	Platform length	SL	44 ÷ 78	55 ÷ 108
6	Pivot angle range	BA	90° ÷ -8°	90° ÷ -15°
7	Hip/lateral support spacing	LPW	12 ÷ 20	17 ÷ 25
8	Hip support height	BSH	15	20
9	Hip support width	BSW	20	25
10	Chest support height	BBH	18	22
11	Chest support width	BBW	20	25
12	Maximum user weight		35 kg	50 kg
13	Total device weight		20 kg	22kg

6. LORI Stander – design

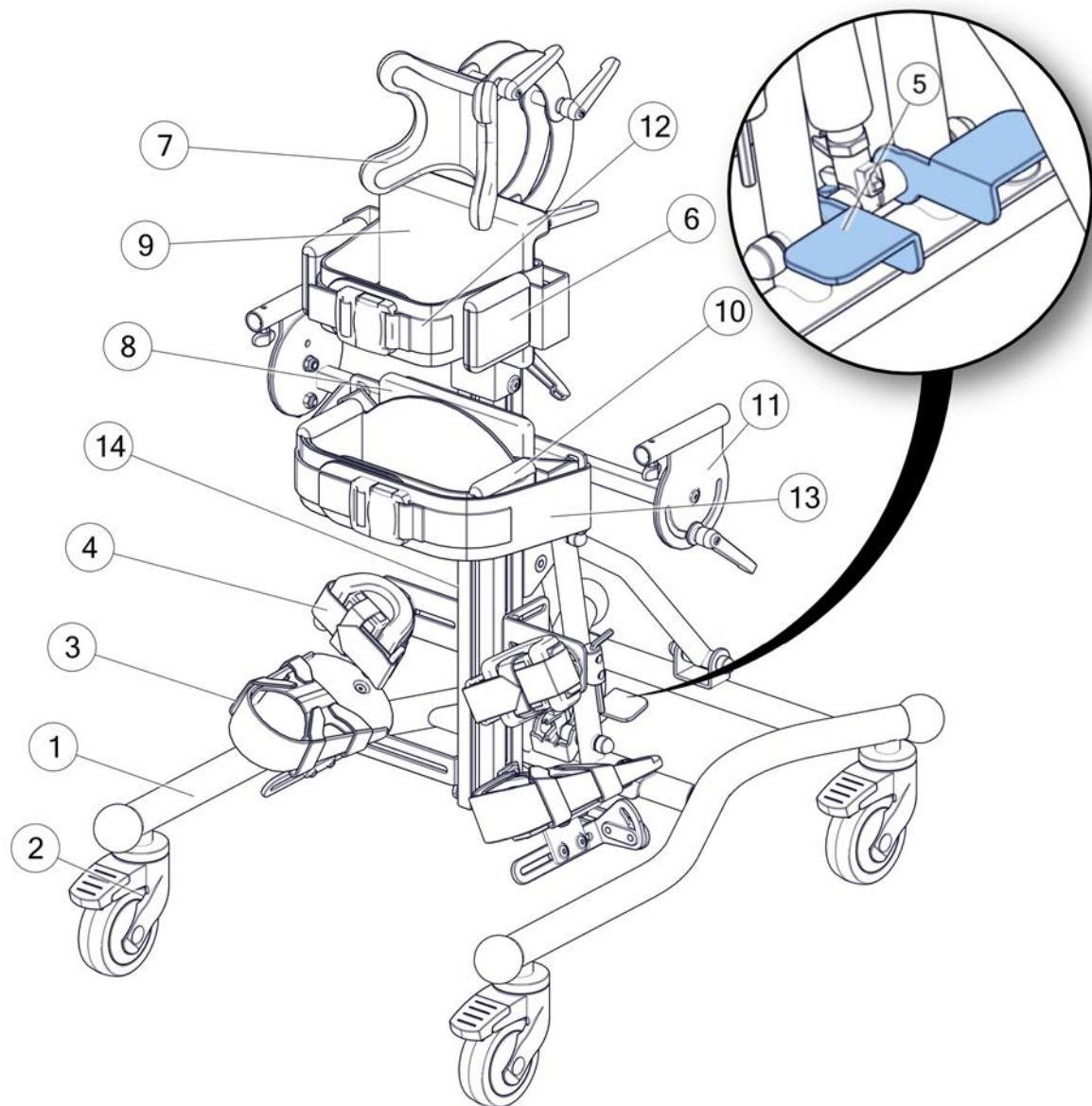

Figure 2

1. Standing frame
2. Wheels
3. Foot platform
4. Knee pad
5. Vertical position release handle
6. Chest support
7. Headrest
8. Main hip support
9. Main chest support
10. Hip support
11. Table support
12. Chest belt
13. Corrective hip belt
14. Column

7. Detailed description of the construction and adjustments of the LORI Stander



CAUTION! After each adjustment, it is crucial to make sure that all assembled and adjusted elements are properly mounted and secured.

7.1. Assembly of the stander



CAUTION! When assembling the frame, special attention should be paid to the possibility of limbs being trapped by moving parts.



CAUTION! After assembly of the device, make sure that all adjusting screws are tight. Loose components may cause the adjustable components to move automatically, which may result in patient injury.

The Stander is delivered in two parts: standing frame and column. In order to assemble the standing frame, perform the following actions:

7.1.1. Disassembly of the frame

To disassemble the frame, first unscrew the screws (1), then set the frame support (2) in the correct position. After setting the frame support, the previously unscrewed screws (1) should be screwed to the frame through the support openings.

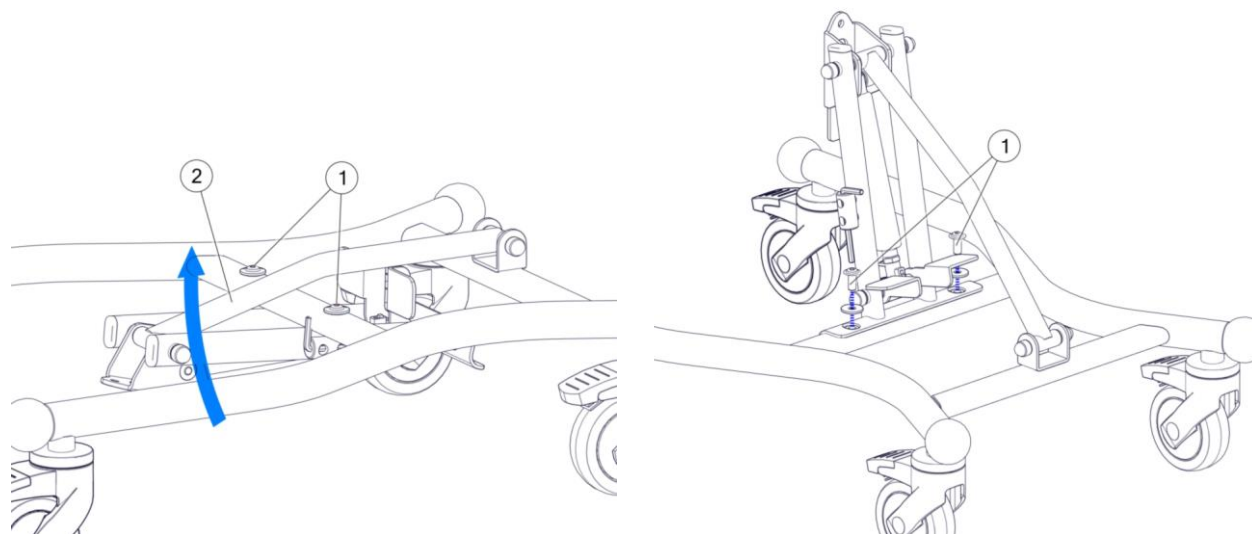

Figure 3

7.1.2. Installation of the column - Figures 4 and 5

To install the column on the standing frame, first unscrew the screws (1) and then place the pin (2) in the opening of the system profile holder (3). When aligning the column, make sure that the distance between the foot platform supports and the frame profiles (see Fig. 5.) is even. The last step of the installation is tightening the frame to the column with the previously unscrewed screws (1).

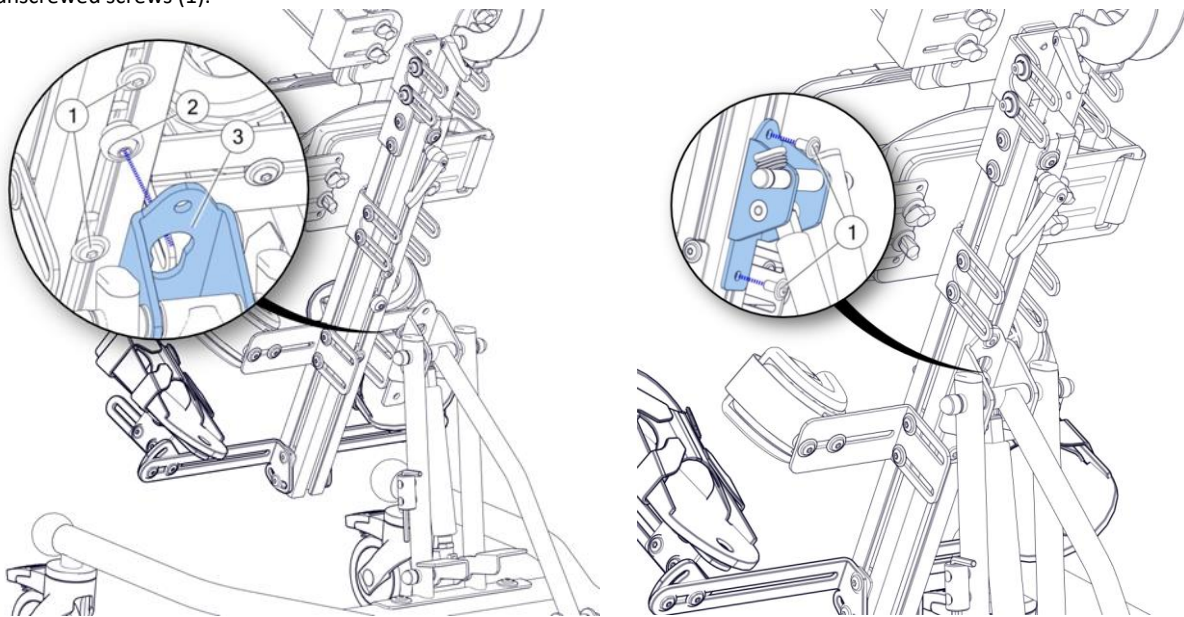

Figure. 4

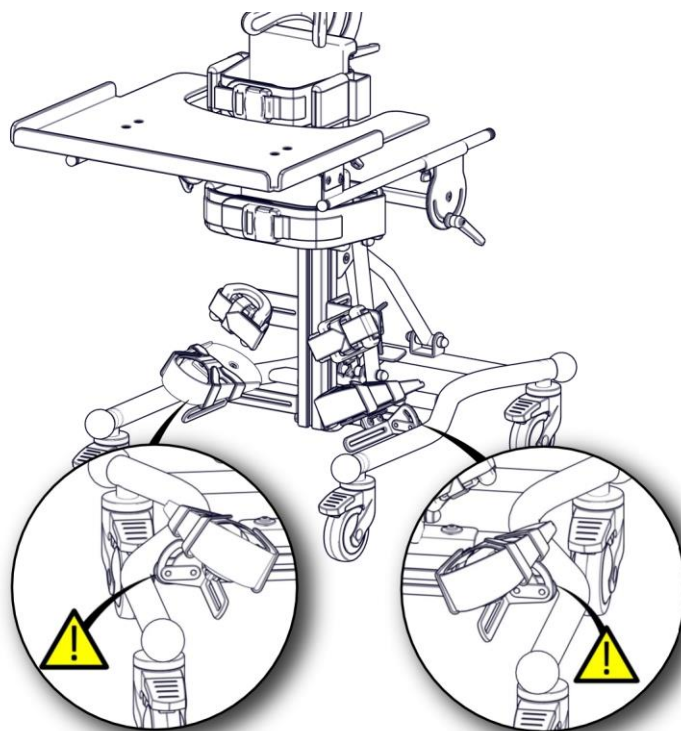

Figure 5

7.2. Wheels – Figure 6

The support frame of the stander is equipped with a set of wheels allowing to move the device indoors. In order to ensure the safety of the patient, each wheel is equipped with brakes blocking the movement of the wheel. Due to safety reasons, the wheels should be blocked when using and adjusting the device. When moving the device, special caution must be taken when moving through door thresholds or other obstacles.

To lock the wheel brake (1), press the brake lever (2) into the lower position. To unlock the brake, pull the same lever upwards.

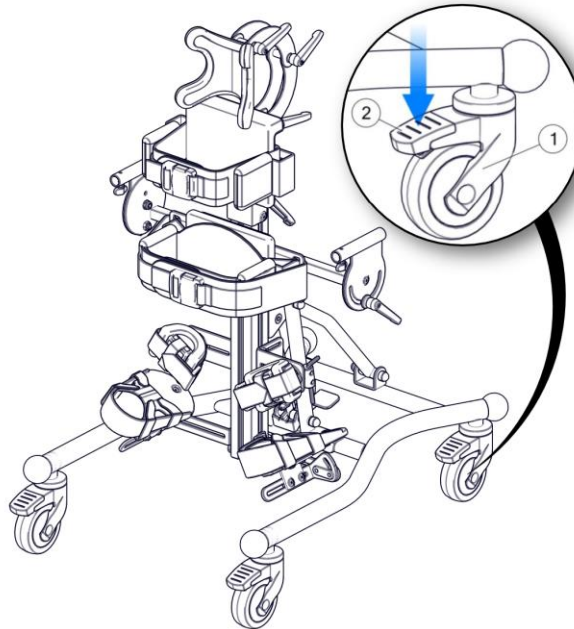

Figure 6

7.3. Main Hip support – Figure 7

The hip support is the main support for the patient. For accurate adjustment to the patient, adjust the position of the support (1) by loosening the screws (2). The hip support can be adjusted in 3 directions: top-down, depth and angled in the lateral plane. Once in the desired position, retighten the screws (2).

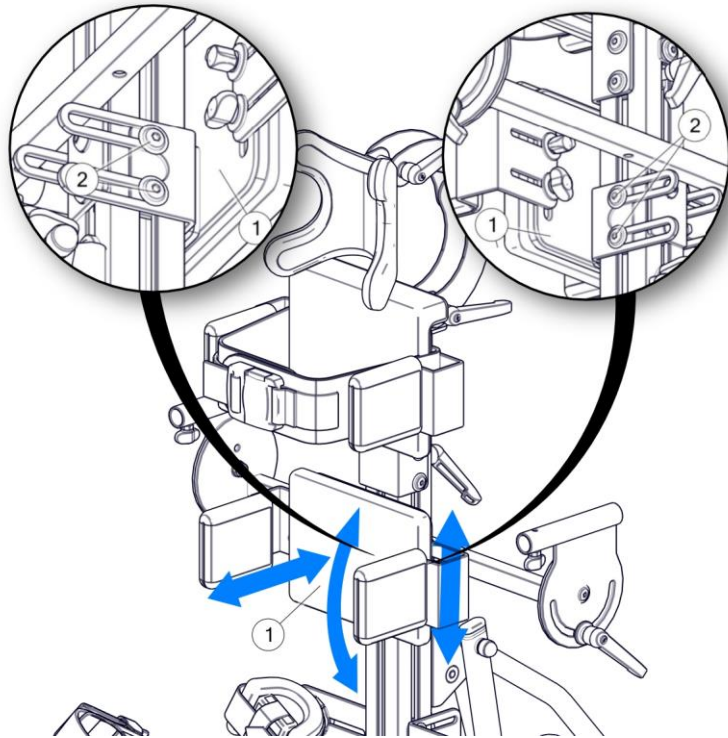

Figure 7

7.4. Lateral support (hip or chest support) – Figure 8

Lateral support is used to support the patient at chest height. To accurately adjust the height to the patient, adjust the position of the support (1) by loosening the screws (2). The chest support can also be adjusted in terms of support depth and angle in the lateral plane. To adjust the depth of the support, loosen the screws (3). Once in the desired position, retighten the screws (2) and (3).

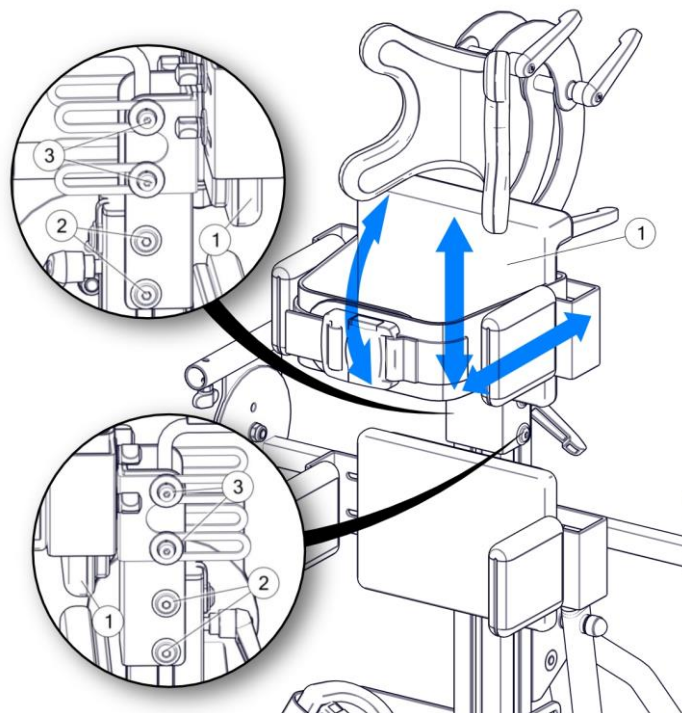

Figure 8

7.5. Adjustment of chest and hip supports – Figure 9

Both chest and hip supports ensure patient stability. The supports are mounted independently which makes it possible to set each support separately.

To adjust the width of the support, loosen the knob (2) (it is not necessary to unscrew it completely) and set the supports in the desired position. After completing the adjustment of the support's position (1), tighten the knob (2) until you feel resistance.

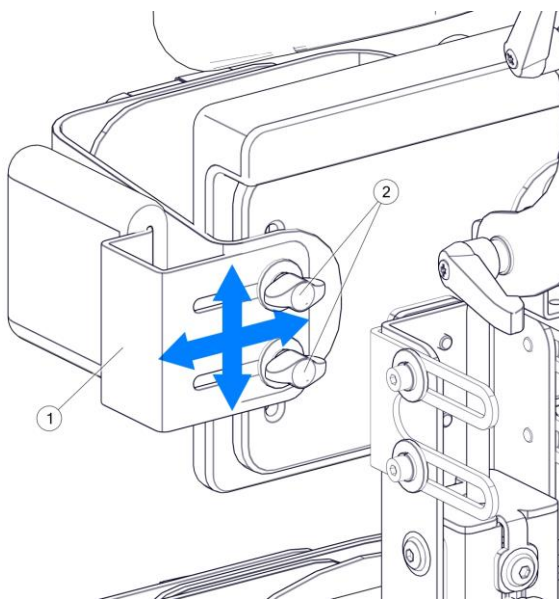

Figure 9

7.6. Chest/hip belt/harness – Figure 10

The chest belt allows for stable patient support at chest height. To release and fasten the belt buckle (1), use the lock button (2) on the upper part of the buckle. The same system is for chest and hip fastening.

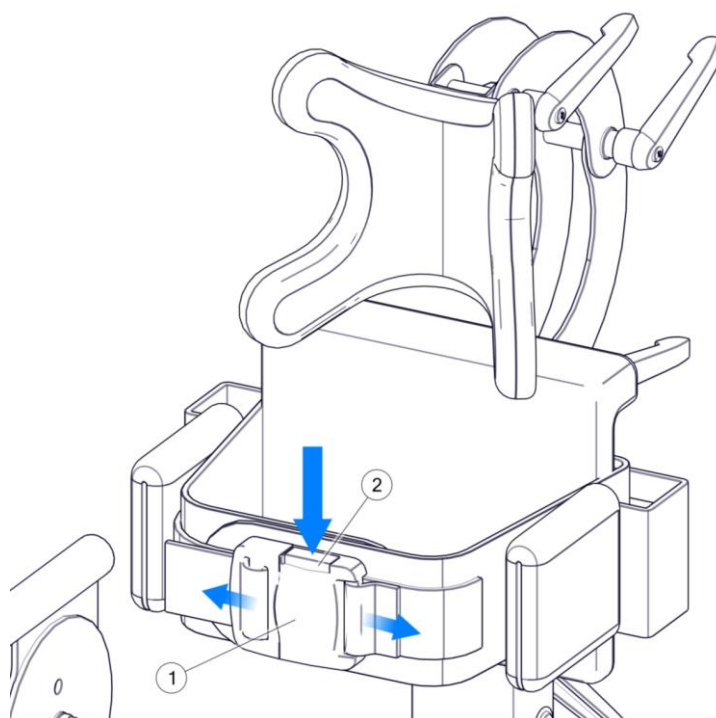

Figure 10

7.7. Knee pads – Figure 11

Adjust the knee pad setting (1) by loosening the screws (3) and then moving the knee pad holder (2) to the desired position. Horizontal position and knee pad rotation (3) can be set after loosening the screws (4). After completing the adjustment, tighten all screws.

Adjustment should be carried out for each knee support separately.



CAUTION! After each adjustment of the kneepad, make sure that all adjustment screws are securely tightened. Unscrewed elements may cause the adjustable elements to shift automatically, which may result in injury to the patient.

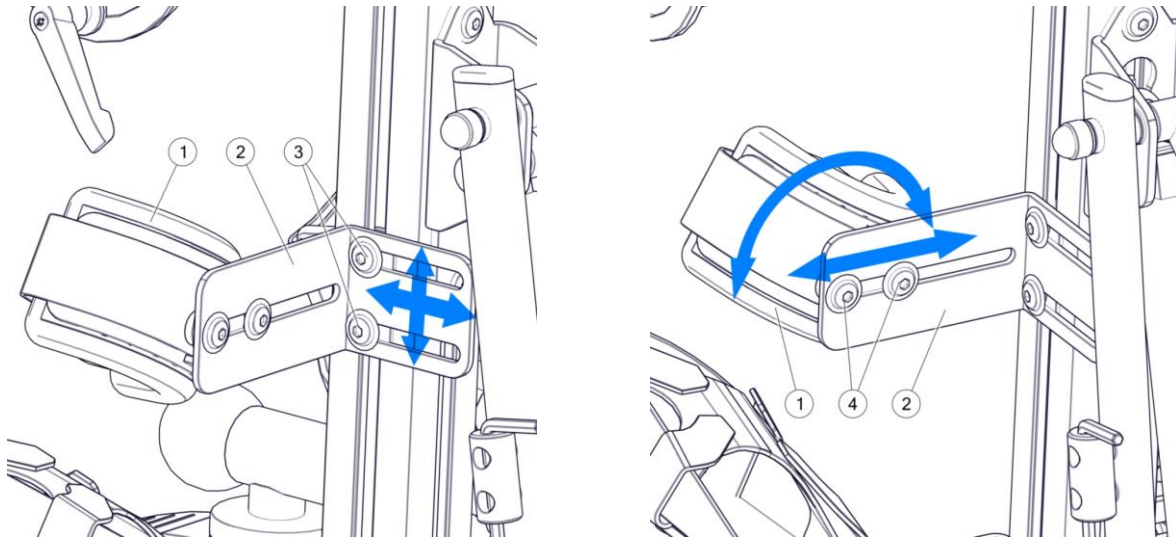

Figure 11

7.8. Foot platforms

The foot platforms used in the stander are fully adjustable in three planes. The tilt angle of the platform is also adjustable. In order to ensure the most precise adjustment to the patient's needs, each platform is adjusted separately.



CAUTION! After each adjustment of the foot platform, make sure that all adjustment screws are securely tightened. Unscrewed elements may cause the adjustable elements to shift automatically, which may result in injury to the patient.

7.8.1. Adjustment of height and tilt of foot platforms - Figure 12

The foot platforms used in the stander enable full adjustment of the patient's foot position. To adjust the height and angle of the foot platform, loosen the screws (2). Then move the platform support (1) along the guide of the stander column. Once the desired position is reached, lock the platform position by tightening the screws (2).

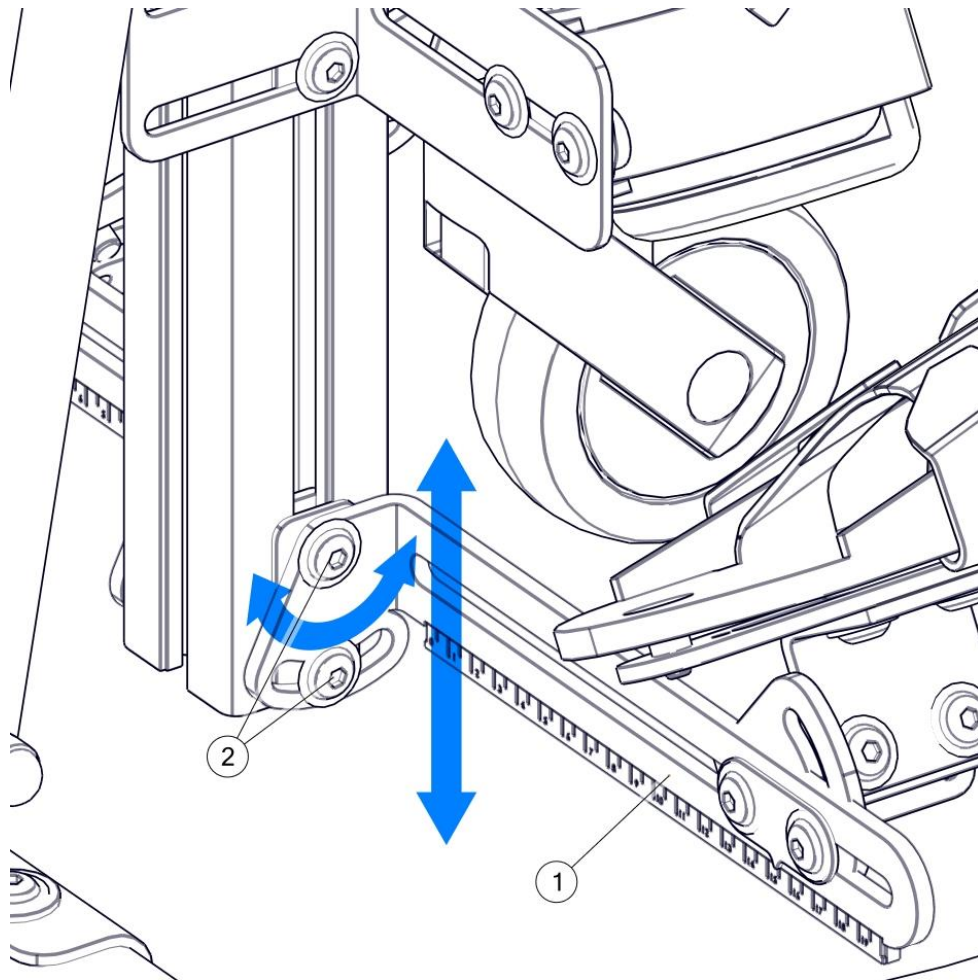

Figure 12

7.8.2. Adjusting the spacing and inclination of the foot platforms

The horizontal position of the foot platform and its tilt can be adjusted after loosening the screws (2). The adjustment allows the foot platform to be moved along the support (1). After completing the adjustment of the platform position, tighten the screws (2). To adjust the right and left platform spacing equally, pay attention to the ruler (1). The indicator (3) must show the same values on the ruler on the right and left.

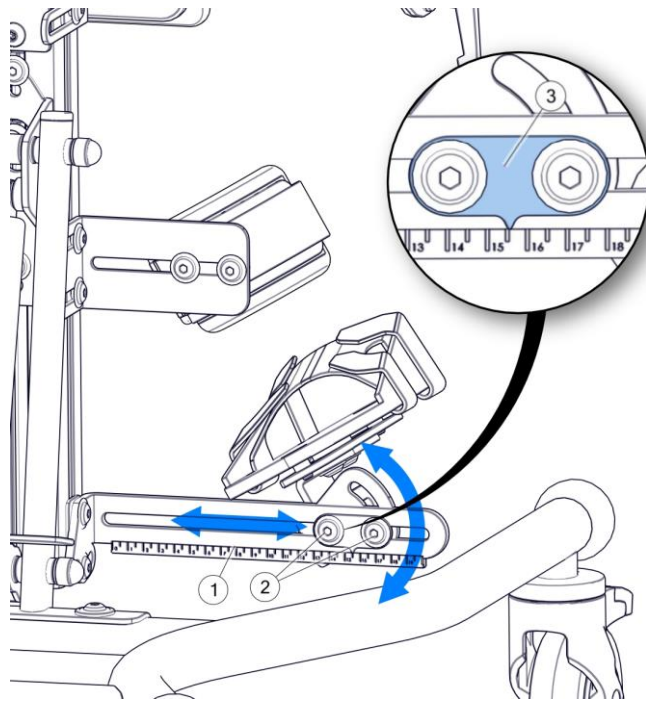

Figure 13

7.8.3. Adjustment (front-back) and rotation of the foot platform - Figure 14

Adjustment (front-back) and rotation of the foot platform is possible after loosening the screws (2) and (3). The adjustment allows the foot platform to be moved in the (front-back) direction. After completing the adjustment of the platform, tighten the screws (2) and (3).

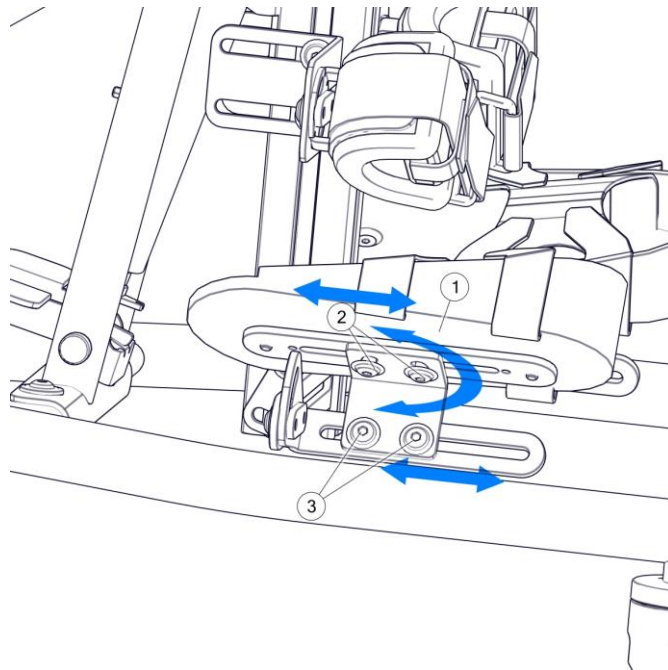

Figure 14

7.8.4. Installation of platforms in forward and reverse vertical position

The stander allows to assume forward and reverse vertical position. To achieve the appropriate type of vertical position, the footrest platforms should be installed in the appropriate direction. To change the direction of the footrest platforms (4), remove the screw (2) and loosen the screw (1) from the locking plate (3), then rotate the platforms 180 degrees. In the next step, screw in the screw (2) and tighten the screw (1).

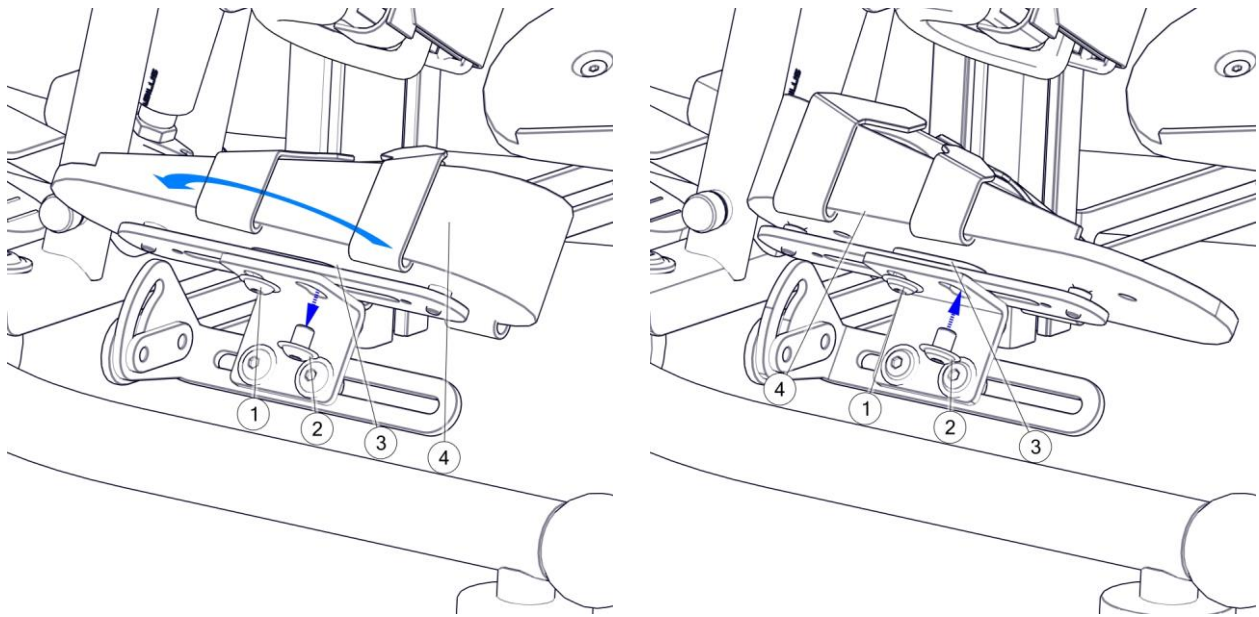

Figure 15

7.9. Vertical position – Figure 16

The patient should always be placed in vertical position with the base wheel brakes locked. The brakes prevent accidental shifting of the device, which could cause uncontrolled repositioning and injury to the patient. The change of position (verticalisation) is supported by the gas spring force. When changing position, it is necessary to fully control and limit the automatic movement of the device by holding the device by hip or chest support.

To change the patient's verticalisation angle, press the release pedal (1) with your leg to release the spring and adjust the position. When performing the adjustment, pay particular attention to the area between the column, base and footrest supports. No objects should be located there, as they may block the movement of the device, resulting in damage to the device or trapping and injuring the patient or the device operator. To lock the adjustment, release the pedal (1), which will lock the gas spring and immobilize it in position.



CAUTION! When adjusting the verticalisation angle, special attention should be paid to the possibility of limbs being trapped by moving parts.



CAUTION! After each adjustment of the verticalisation angle, make sure that the gas spring is locked and that the hip and chest support position does not shift automatically.



CAUTION! When placing the patient in a vertical position, the device's wheel brakes should be locked. Uncontrolled movement of the device may cause injury or trauma to the patient.

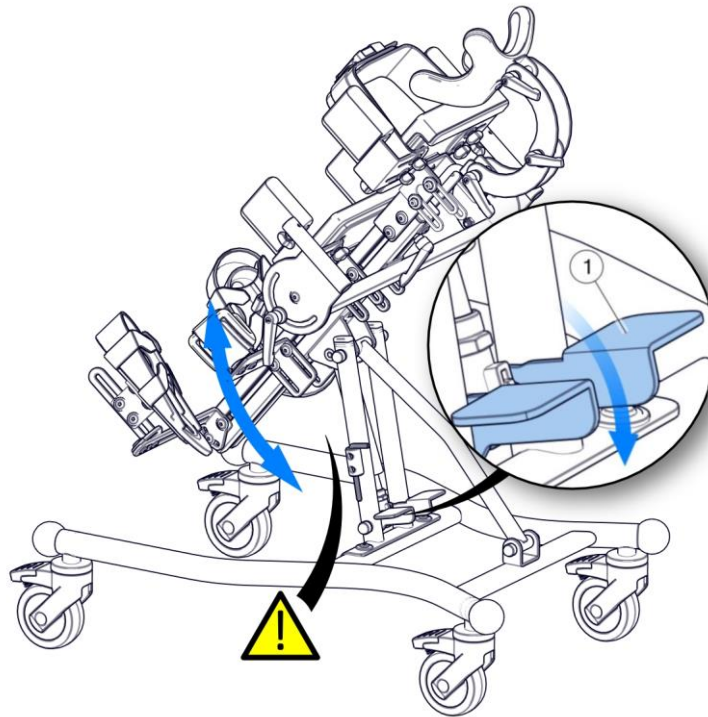

Figure 16

7.10. Blocking the release button.

See Figure 17

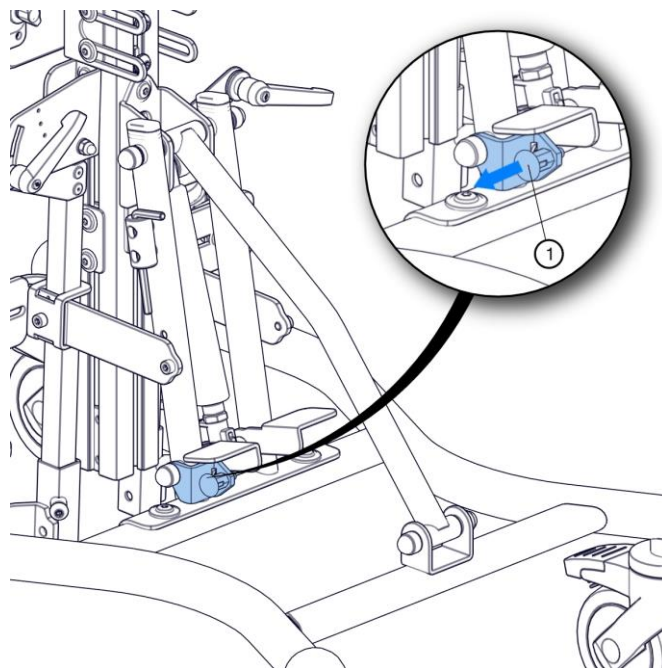

Fig. 17

Lori stander is equipped with a release button for verticalization. In order to open the blockade of the release button move element 1, and then turn it by 90 degrees. In order to close the blockade, do these steps in reverse order.



CAUTION! Do not leave the patient on the stander with an open blockade of the release button.

8. Accessories

8.1. Tray

8.1.1. Adjustment of the tray tilt angle – Figure 18

To adjust the tray tilt angle (1), loosen the screws (3) and the adjustment handles (2). Once the angle has been set, tighten the knobs (2) and screws (3) to lock the traytop in position.

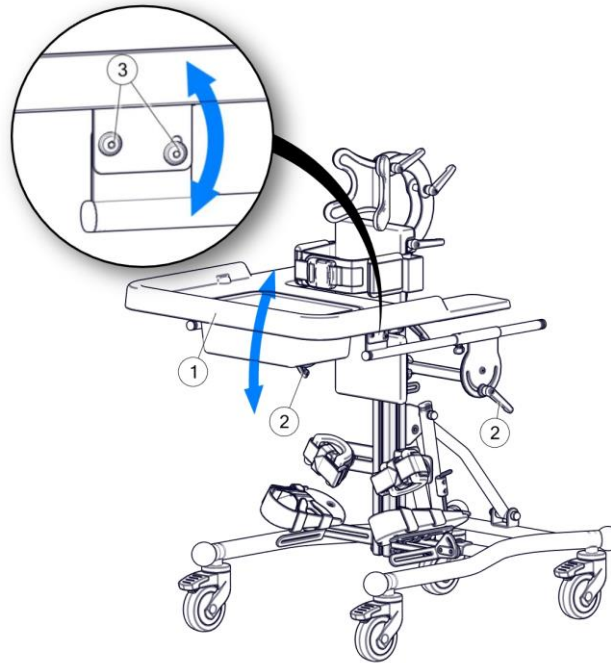

Figure 18

Adjustment of the height and the front-back position of the tray - Figure 19

To adjust the front-back position of the tray, loosen the knob (4), which allows you to move the arms (3) of the table. The height of the tray is adjusted by loosening the screws (2), which makes it possible to move the entire table structure in the vertical axis.

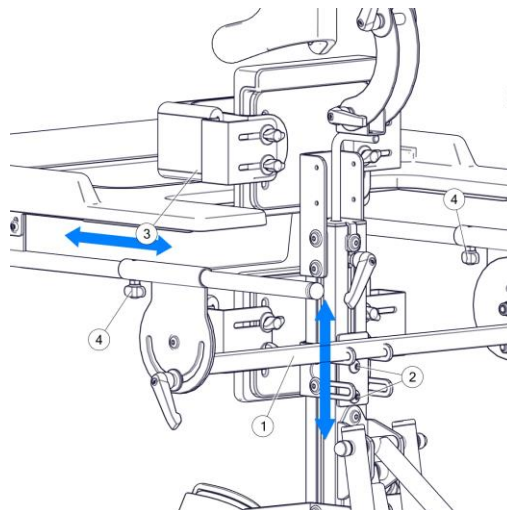

Figure 19



CAUTION! When disassembling the table, it is essential to secure the table guides with plugs.

8.2. Headrest for supine position – Figures 20 and 21

To install the headrest, insert the headrest holder rod (1) into the opening in the upper part of the stander column. Then adjust the height of the headrest and use the knob (2) to prevent the headrest from sliding out.



CAUTION! After each adjustment of the headrest, make sure that all adjusting elements are securely tightened. Unscrewed elements may cause the adjustable elements to shift automatically, which may result in injury to the patient.

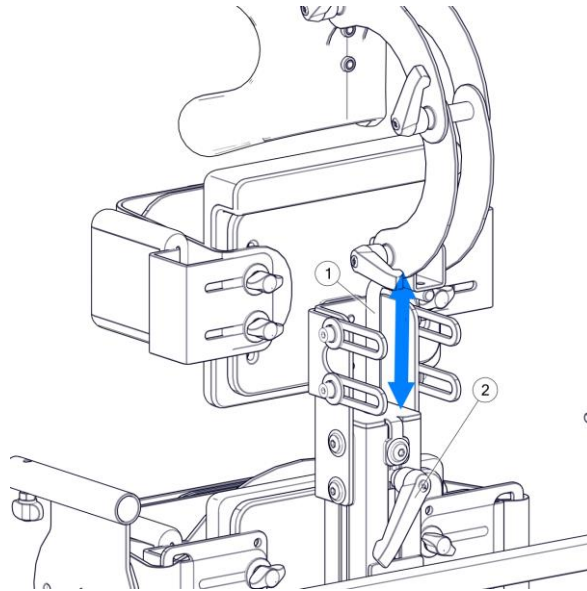

Figure 20

To adjust the headrest (1), loosen the adjusting knobs (2), move the headrest to the desired position and tighten the knobs (2).

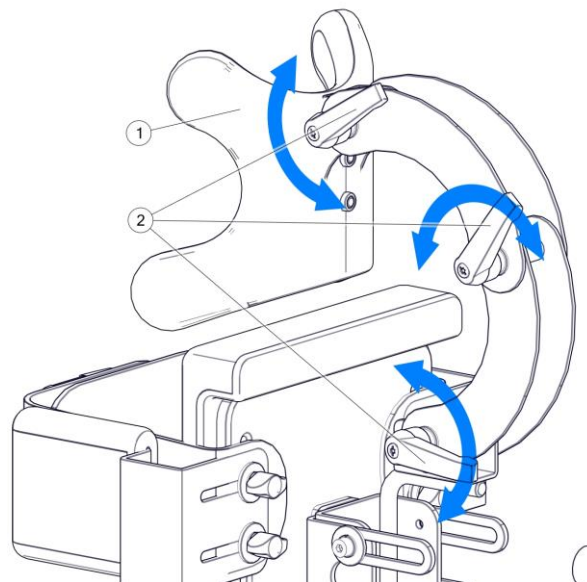

Figure 21

8.3. Corrective hip strap - Figures 22 and 23

The corrective hip strap is an additional option allowing to stabilise the patient at hip height. To install the belt, remove the hip supports (1) by loosening the knobs (2). Then use the knobs (2) to screw in the hip strap support (3).

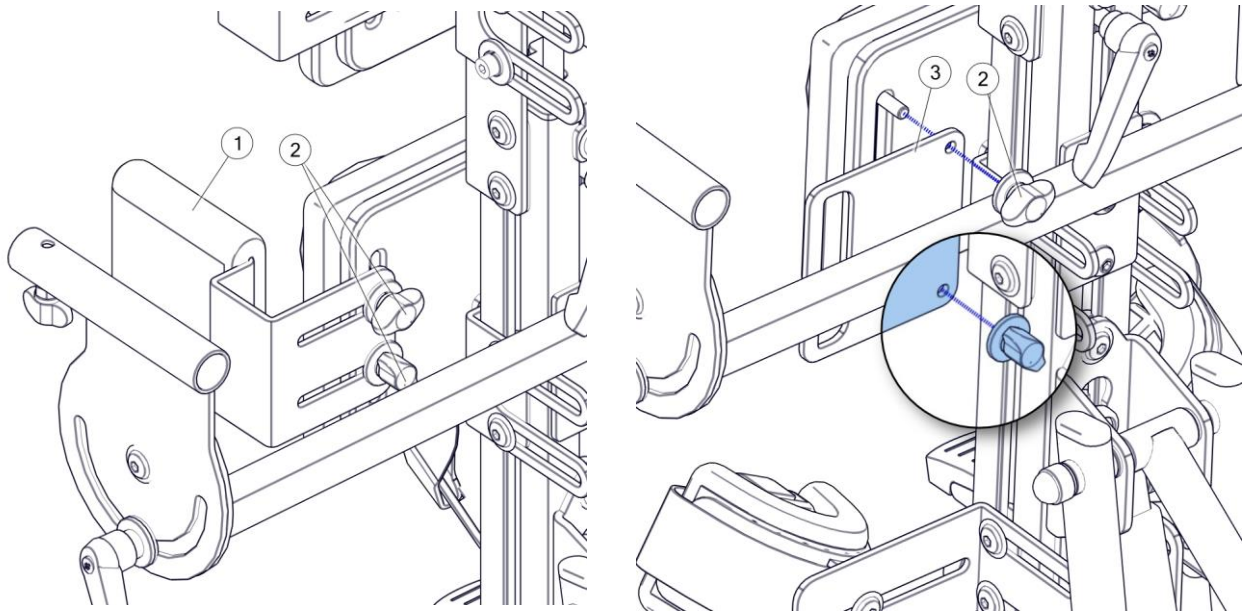

Figure 22

Finally, pass the strap (4) through the slots in the corrective hip strap support (3). To release and fasten the belt buckle, press the buckle locking button (5) on top of the buckle.

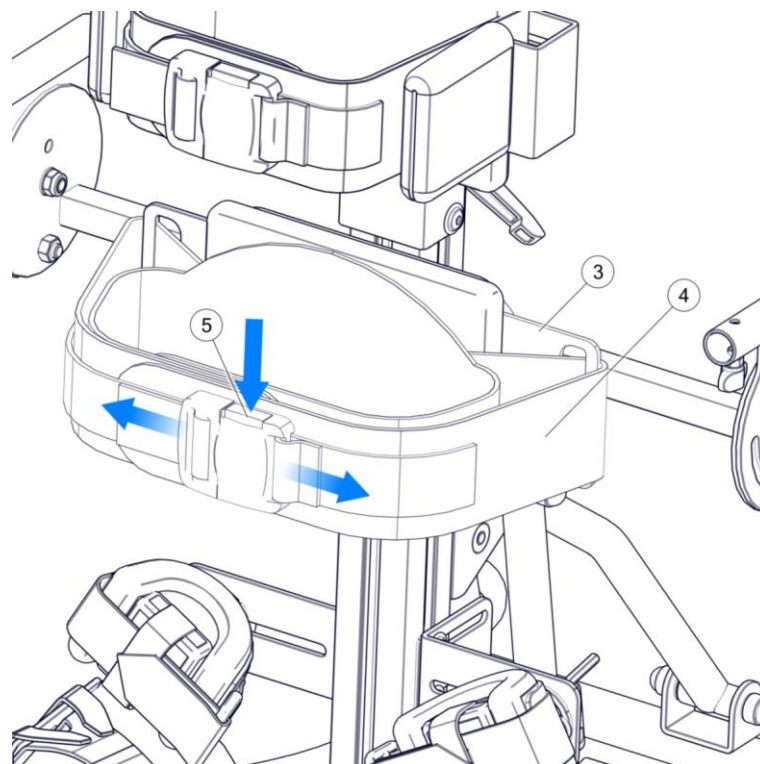

Figure 23

8.4. Shoulder protectors – Figure 24

In the case of rear verticalisation, shoulder support is sometimes required for the safety and comfort of the user.

The Lori stander offers an accessory that makes this possible. To adjust the front angle, loosen the knobs (4), then set the required angle and tighten the knobs when the adjustment is complete. To change the depth and tilt in the upper plane, loosen the screws (3). After adjusting the angle and depth, tighten the screws (3).

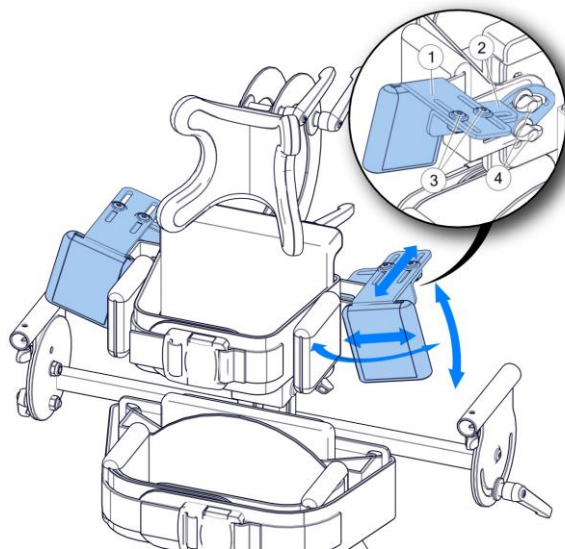

Figure 24

8.5. Fastened SideUP chest supports (flip away laterals) – Figure 25

To release the support, press the red button of the buckle (see), then lift the support (1) and tilt it. Proceed with the second support in the same way. The tilted supports make it easier to place the patient in the device. To re-fasten the SideUP supports, tilt them back until they snap back into their base position.

The SideUP supports can be adjusted in two directions by loosening the knob (2) and tightening the knobs (2) after adjustment (2)

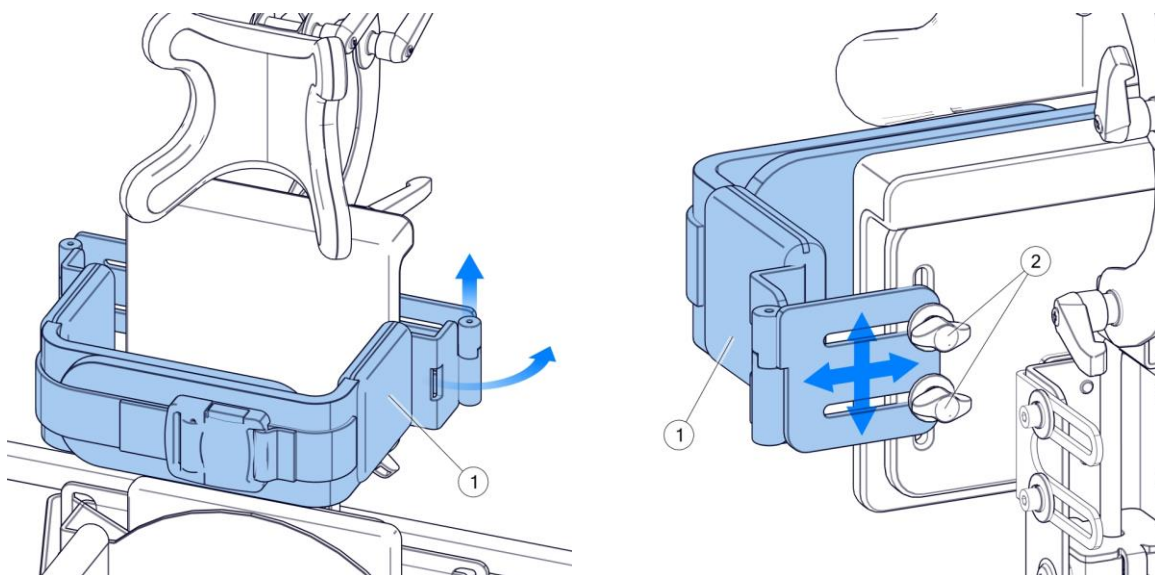

Figure 25

8.6. Installation and adjustment of the vest

See Figure 26

To fix the vest, start with mounting the adapters, which can be screwed in the place where chest pelotte pads and pelvis pelottes can be fixed. After fixing the adapters, pull the vest belts through the buckles in points 1, 2, 3 and 4, as shown in the figure below.

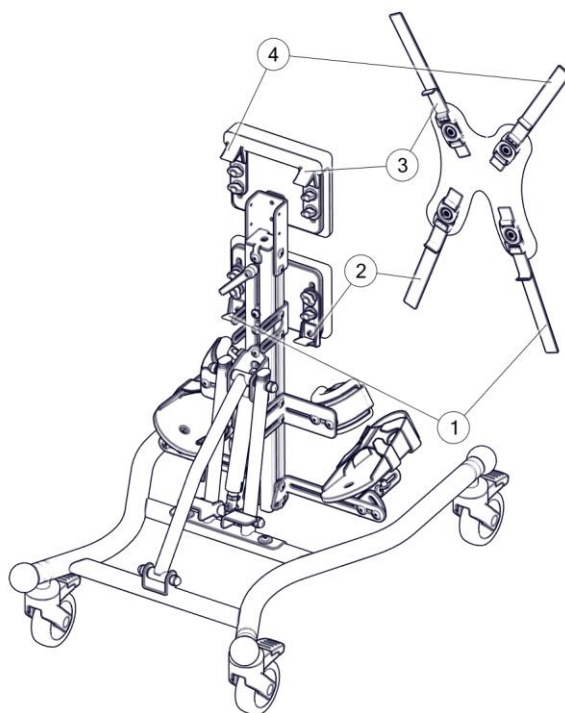

Figure 26

8.7. 3D Pelvic & Hip support and positioning system

See Figure 27

To fix the back support, start with placing the caps (2) in the hole of the stander column. After inserting the caps, fix the back support handle with screws (1). The handle should be placed at the right height, depending on the height of the patient, and then tighten the screws (1).

See Figure 28

Before placing the patient in the stander, it is important to remove the back support. In order to do so, please unscrew the knob (1) and pull out the back support. Then, we fold the blocking element of the back support bracket, unhooking it from the handle by pulling it away with the strip (2).



CAUTION! Carefully check whether the blocking element of the back support is properly set within the handle. Inaccurate setting of the blocking element in the handle may lead to automatic disconnection of the blocking element, which in consequence may result in folding of the back support and the patient may lose his or her stability, and this may lead to injuries.



CAUTION! When adjusting the disconnection of the back support bracket, it is crucial to remain particularly careful, as moving elements may cause hand injuries.

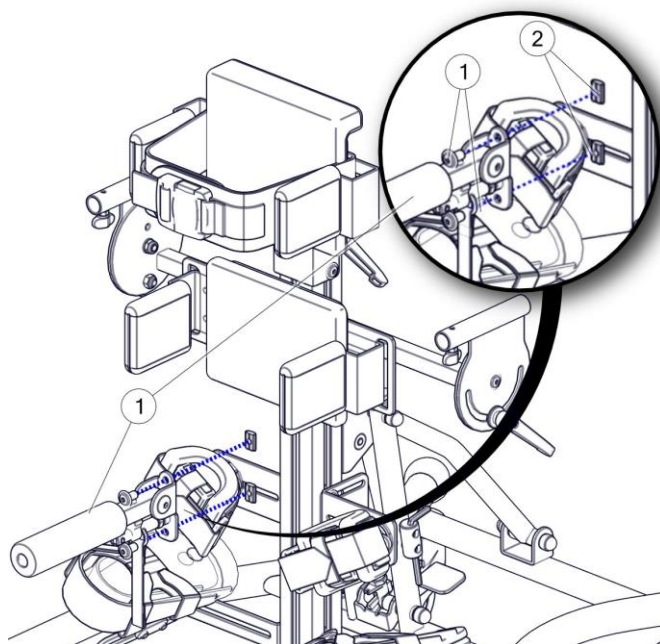

Fig. 27

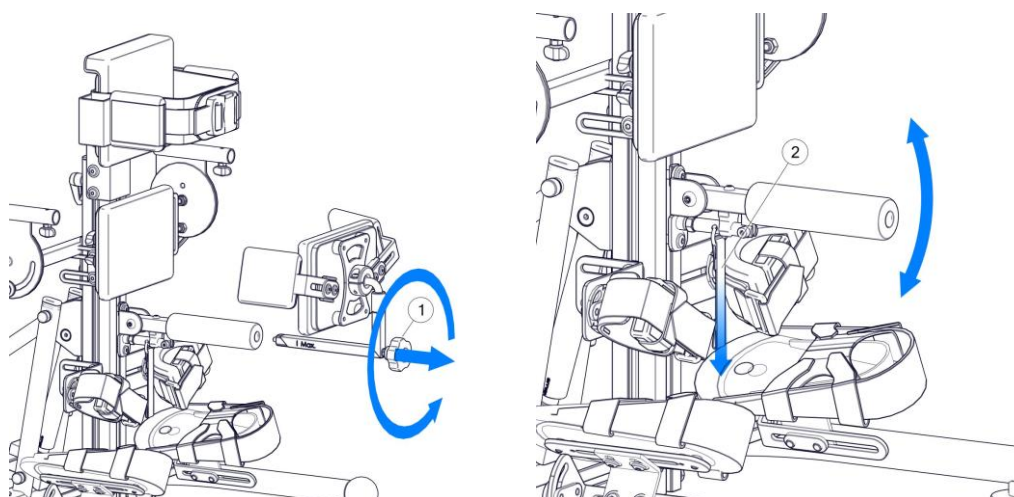

Fig. 28

After placing the patient in the device, fix the back support bracket and block it. The back support bracket enables precise adjustment within all planes. After setting the depth of the back support, tighten the knob (1) (Fig. 28) and hence block the possibility to pull out the back support. The maximum distance of the depth of the back support is indicated with the "MAX" mark. The height of the back support may be adjusted by loosening the screw (2) (Fig. 29). After adjusting the height of the back support, block the back support by tightening the screw (2) to the limit. Precise adjustment of the plane of the cushion supporting the back can be obtained through loosening the screws (1) (Fig. 28), and then it is crucial to adjust the location of the back support and tighten the screws once again (1).

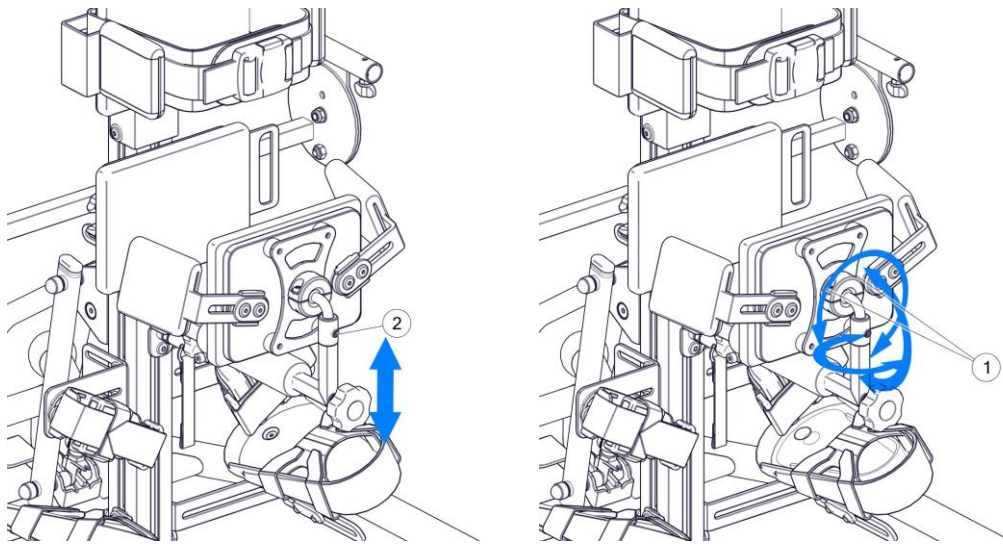

Fig. 29

8.7.1. Adjustment of the pelvic pelottes of the back support

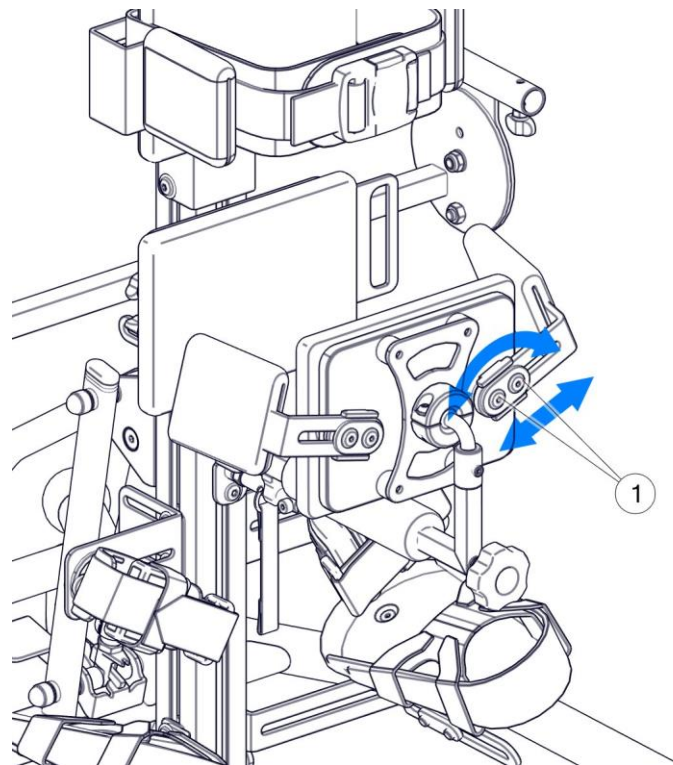

Fig. 30

See Figure 29

Pelvic pelottes of the back support can be adjusted within the scope of their width, as well as abduction angle. In order to make the adjustment, loosen the screws (1), set the width of the back and the angle, and then tighten the screws.

8.8. Installation and adjustment of the head support for the front stabilisation.

See Figure 30

Prior to fixing the head support for front stabilization, remove the upper part of the back pelotte by loosening the screw (1). Place the head support on the adapter of the back pelotte and then tighten the head support with a screw (2).

See Figure 31

The head support is fully adjustable, as far as depth, height and sides are concerned. Proper adjustments can be made by loosening screws (1), (2), (3) and (4). Loosening screw (1) allows to adjust the angle of the head support. Screw (2) allows to adjust the head support in the up-down axis. Screw (3) enables to adjust the head support to the sides. Handles (4) allow to adjust the angle of the head support, along with its depth.

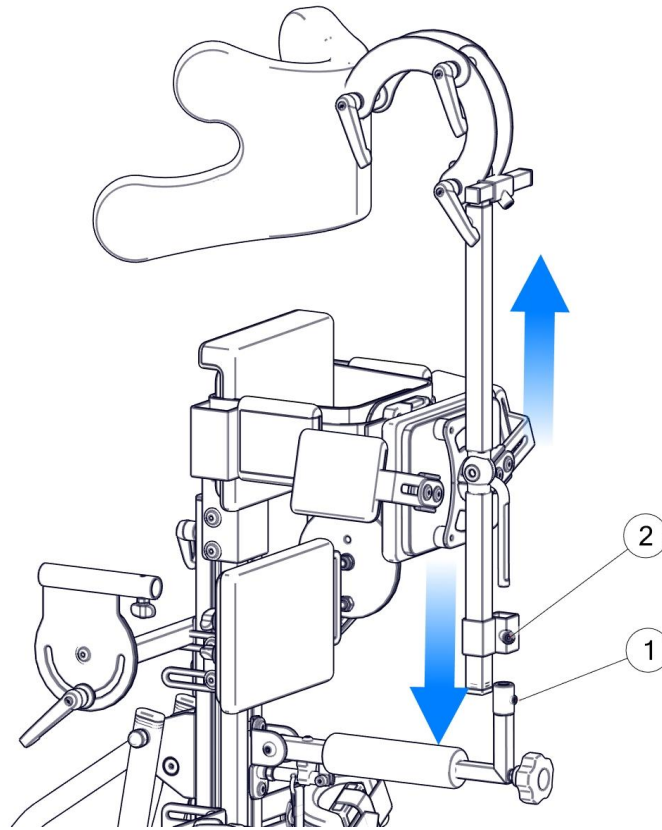

Fig. 31

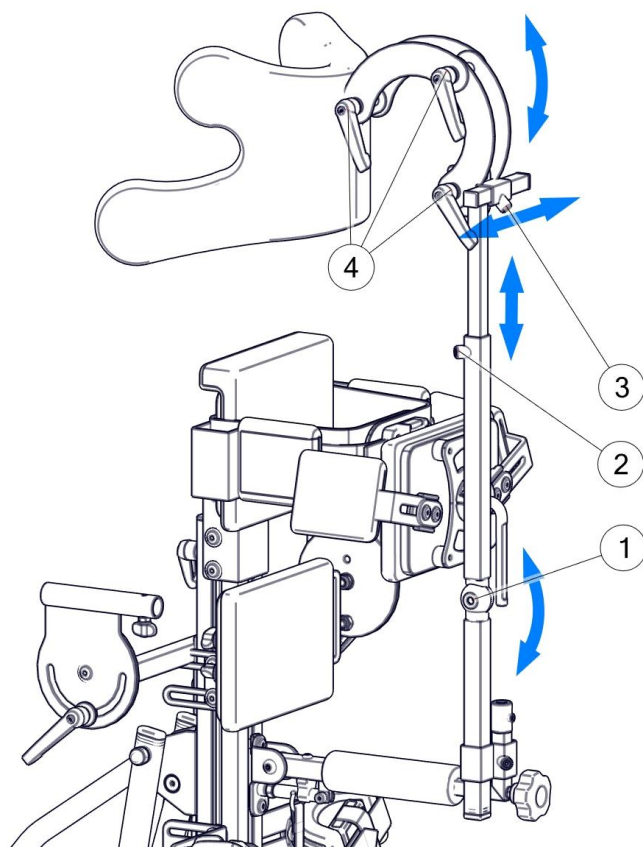

Fig. 32

8.9. Installation of the leg abduction adapters.

See Figure 32

Fix the adapters (1) by inserting the screws (3) into the holes within the stander column. Tighten the adapter (1) by tightening the screws (2). When mounting the adapters, pay special attention to the symmetric position of the right and the left leg abducting adapters – they need to be at the same height.

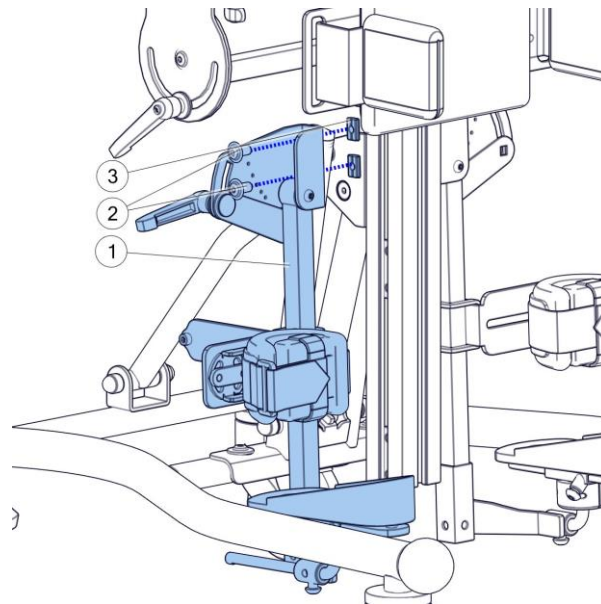

Fig. 33

8.9.1. Knee pads of leg abduction adapters.

See Figure 33

In order to adjust knee pads (1), loosen the screw (3), and then move the handle of the knee pad (2) to the desired position. After loosening the screws (4), it is possible to adjust the proper horizontal position and to rotate the knee pad (1). After adjusting all the elements, tighten all the screws. Repeat the adjusting procedures separately for each of the knee pads.



CAUTION! After each adjustment of the knee pad, make sure that all the adjusting screws have been tightened. Loose screws may result in an automatic shift of the adjusted elements, and this can lead to patient's injuries.

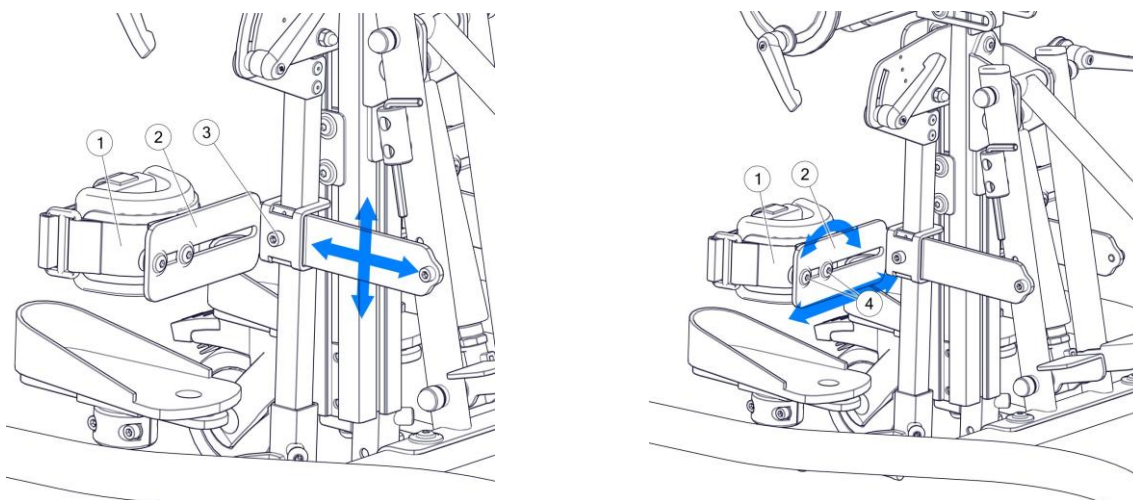

Fig. 34

8.9.2. Feet platforms for leg abduction adapters.

Feet platforms for leg abduction adapters used in the stander enable complete adjustment within three planes. It is also possible to adjust the tilt angle of the platform. In order to ensure the most precise adjustment to meet the requirements of the patient, each platform can be adjusted separately.



CAUTION! After each adjustment of the feet platforms, make sure that all the adjusting screws have been tightened properly. Loose elements may result in an automatic shift of the adjusted elements, and this can lead to patient's injuries.

8.9.3. Adjustment of the height of feet platforms for leg abduction adapters.

See Figure 34

Feet platforms used in the stander make it possible to fully adjust the position of the patient's foot. In order to adjust the height of the feet platform, loosen the screw (1). Then, shift the platform until you reach the desired height. After reaching the desired height, block the position of the platform by tightening the screw (1). Repeat the same procedure to adjust the second platform.

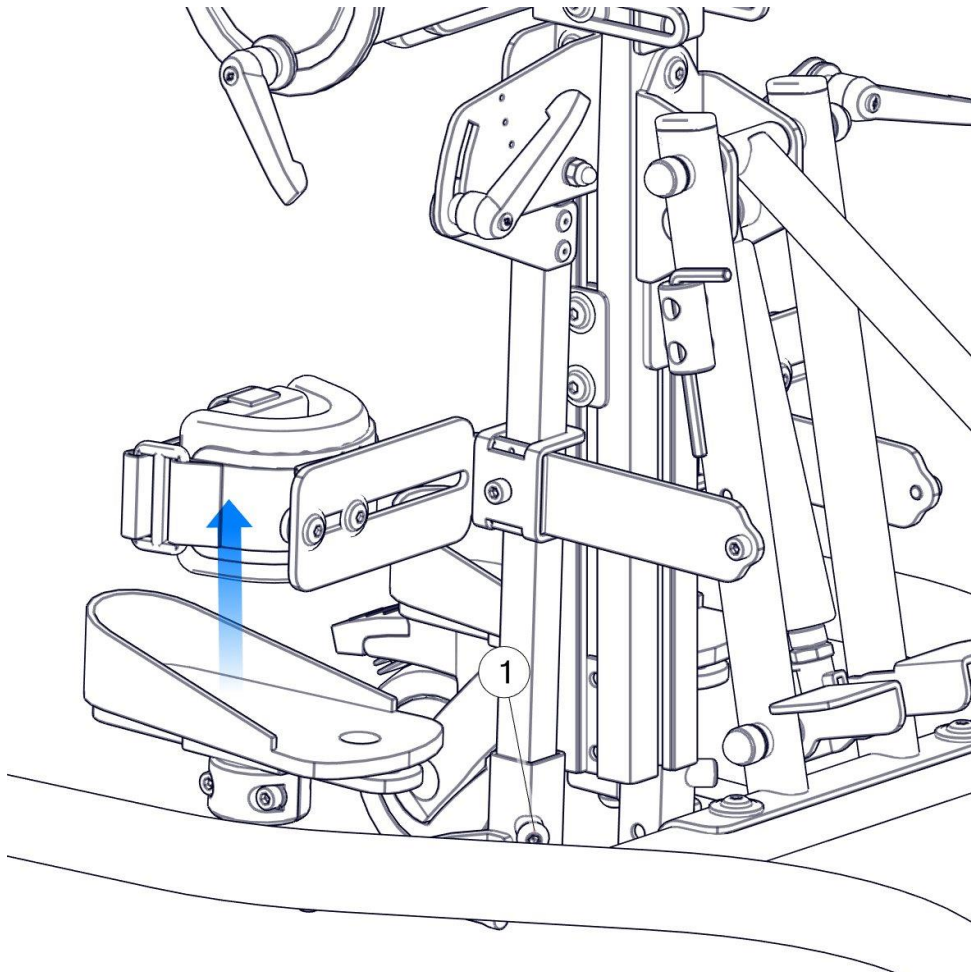

Fig. 35

8.9.4. Adjustment of the tilt of feet platforms for leg abduction adapters

See Figure 35

In order to adjust the tilt of the feet platforms (1), loosen the screws (2). It is possible to adjust the angle of the platform within 3 planes. After adjusting the position of the platform, tighten the screws (2).

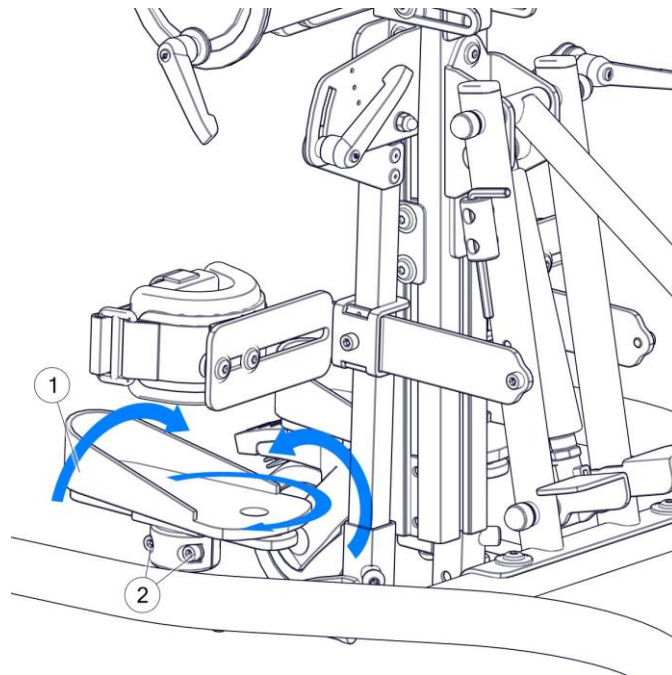

Fig. 36

8.9.5. Adjustment (front-back) of the feet platform for leg abduction adapters

See Figure 36

The adjustment (front-back) of the platform can be performed after loosening the screws (1). The adjustment allows to move the foot platform (front-back). After reaching the desired position, block the position of the platform by tightening the screws (1).

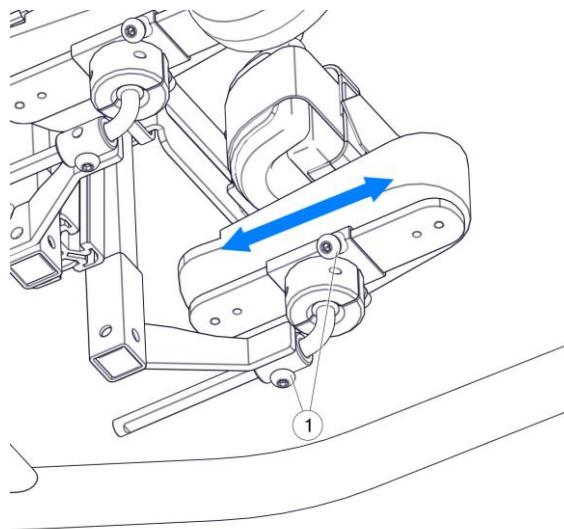

Fig. 37

8.9.6. Installation of the knee pad in front and supine verticalization in leg abduction adapters.

See Figure 37

The stander allows front and back verticalization of the patient. In order to verticalize the patient in the desired position, it is crucial to install proper knee pads and ensure proper direction of the knee pads. TO change the direction of a knee pad (1), unscrew the screws (3) and then rotate the knee pads by 180 degrees. Then tighten the screw (3).

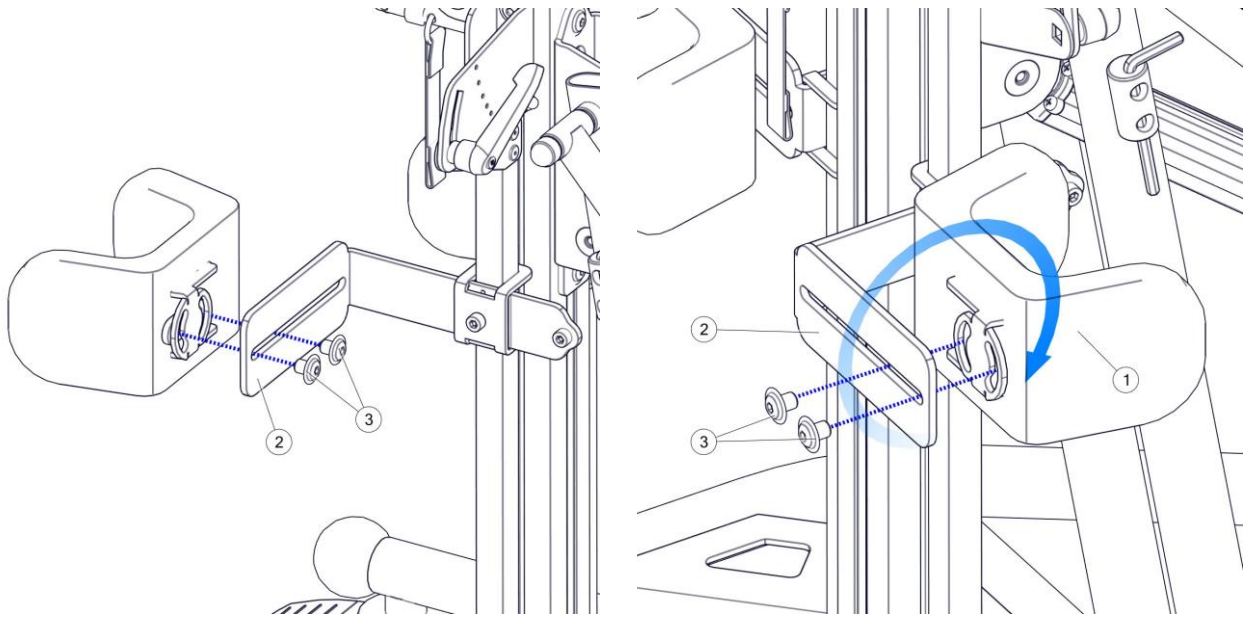

Fig. 38

9. Cleaning and maintenance

LORI Stander is a mechanical device with a supporting structure made of steel and aluminium covered with a powder coating. A sponge-foam insert is attached to the metal structure and fitted with a cover made of textile fabrics.

The LORI stander, like any medical device, should be kept clean and used according to the manufacturer's recommendations.

9.1. Recommendations for cleaning and maintenance

Clean paint coatings with a cloth dampened with water. The use of mild agents for cleaning household appliances is allowed.

Guidelines for upholstery washing:

- Remove sponge inserts from the covers before washing.
- The covers should be washed by hand or in an automatic (tumble) machine at 30 C.
- Use PZH-approved detergents for delicate products in quantities specified on the package.
- For children prone to allergies, use grey soap or special detergents.
- To remove excess water – use a short spin cycle, do not wring.
- Drying – hang to dry at room temperature. DO NOT TUMBLE DRY.



CAUTION! WHILE WASHING THE UPHOLSTERY COVERS, PARTICULAR ATTENTION SHOULD BE PAID TO THE VELCRO FASTENERS. TO PREVENT ANY DAMAGE TO THE UPHOLSTERY, ENSURE THE VELCRO FASTENERS ARE UNFASTENED DURING THE WASHING AND THAT THEY DO NOT COME IN TO CONTACT WITH THE UPHOLSTERY.



CAUTION! Do not wash the foam inserts.

The sponge-foam insert:

- Should be vacuumed mechanically or cleaned using a soft-bristled brush.
- Can be washed with a damp cloth and a mild detergent, then dried thoroughly at room temperature.

9.2. Disinfection

If the device is used by different people (e.g. in a rehabilitation centre), disinfectants should be applied. For manual disinfection of metal and plastic parts of the product, INCIDIN PLUS in a concentration of 0.25% to 0.5% or similar disinfectant is recommended.

Please follow the manufacturer's instructions for use of the disinfectant.



CAUTION! The device should undergo maintenance, performed by a qualified service technician, at least once a year (every 12 months). During maintenance, the safety of the device should be checked - the condition of the movable connections, snap-in and adjustment mechanisms should be checked. Periodic inspections of the device ensure long-term and problem-free operation.



CAUTION! The device is not waterproof. Do not allow the device to come into direct contact with water. Use the device indoors at room temperature. Do not expose the device to direct contact with weather conditions.

10. Nameplate

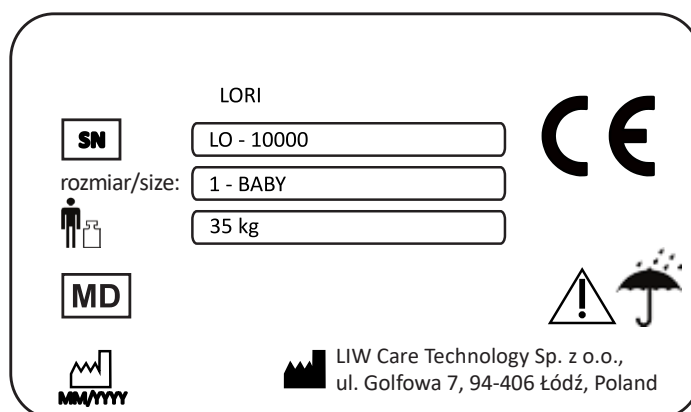

Figure 39

11. Warranty/Service

If any defects or damage are noticed, stop using the device immediately and contact the seller or manufacturer. Protect a defective device to prevent the damaged area from expanding. Do not attempt to repair the unit yourself. Do not replace the original parts of the device with parts made by yourself or obtained from other sources than recommended by the manufacturer.

- If the user decides to discontinue the operation of the device, he is obliged to dispose of it in accordance with environmental regulations.
- The manufacturer determines the product life to be 5 years.
- The post-warranty service of the device is performed by the manufacturer.

Contact details of the service department:
LIW Care Technology Sp. z o.o., ul. Golfowa 7, 94-406 Łódź.
www.liwcare.pl
e-mail: reklamacje@liwcare.pl

- Current address details are available at www.liwcare.pl.
- Terms of the warranty have been specified in the warranty card which constitutes an integral part of this user manual and is available on the last page.



WARRANTY CARD

Terms of the warranty:

1. LIW Care Technology Sp. z o.o. (ul. Golfowa 7, 94-406 Łódź), the manufacturer of rehabilitation equipment, guarantees that the device purchased by a consumer or other user is technically efficient, free from defects in design, assembly, materials, etc. and that the device will remain free from these defects during the warranty period. The warranty does not cover ensuring the usefulness of the product for the buyer's needs.
2. LIW Care Technology Sp. z o.o. provides a two-year warranty on its products from the date the product is released to the consumer.
3. This warranty card issued by the seller to the purchaser together with the proof of purchase (invoice or receipt) stands as the only evidence of warranty. Transfer of rights under the warranty requires the transfer of ownership of the warranty card and proof of purchase.
4. If a defect or damage to the device is discovered during the warranty period, it will be removed free of charge by repairing the device or replacing it. If a part of the product needs to be replaced, the damaged part becomes the property of LIW Care Technology Sp. z o.o. and is not refundable to the user of the warranty.
5. The warranty user is obliged to report any physical defects in the goods discovered during the warranty period, using the Complaint Form. The file with the complaint form is available at www.liwcare.pl website in the "Products" section, and its physical copy is an appendix to the instructions provided to the Purchaser together with the Equipment. The form can also be obtained from any of our Regional Sales Specialists who can be contacted through our website at www.liwcare.pl/kontakt. In case of problems obtaining the Complaint Form, please contact us at 0-42 212-35-18.
6. The warranty user is obliged to fill in the complaint form and send it to the Store where he purchased the equipment or directly to the Manufacturer at the e-mail address reklamacje@liwcare.pl.
7. On the basis of the complaint form received by e-mail, the Seller decides on the method of repair. The Seller may:
 - a) Order the repair of the equipment on site with the Warranty User - in such an event, the date of the repair of the device is agreed with the notifying party via e-mail or telephone.
 - b) Order the transport of the device to the Manufacturer in order to perform its repair - in such event, the Warranty User shall be obliged to deliver the equipment to the medical store where it was purchased or to the seat of the Manufacturer, together with a proof of purchase and a completed complaint form. The Goods subject to complaint are sent to the Seller after arranging the date of its collection by the courier. Delivery costs are incurred by the Manufacture.
8. The warranty does not cover the following:
 - a) worn-out elements and parts that have been worn or damaged due to improper use (including, but not limited to as a result of use not complying with the issued user manual or in inappropriate conditions) or inappropriate storage of the product,
 - b) damage caused by alterations, adjustments, adaptations and design changes made by the user of the product or third parties,
 - c) damage caused by improper cleaning or maintenance by the user of the product or third parties,
 - d) damage caused by normal wear and tear or normal ageing of the product,
 - e) damage caused by negligence on the part of the user of the product (including, but not limited to cleaning and maintenance of the product),
 - f) damage caused by external factors (mechanical damage, contaminations, including flooding).
9. The warranty and the terms listed therein are only applicable within the territory of the Republic of Poland. For another country, contact your local distributor.
10. The warranty shall not cover adjustment and fitting performed within the warranty period, as these do not constitute any defects of the product.
11. The warranty is conditional on delivery of the product to the medical store where the device was purchased or to the Manufacturer in a manner that prevents its damage.
12. If possible, the warranty repair or warranty replacement shall be performed within 30 days of delivery of the device to the Manufacturer.
13. After the warranty repair, the equipment shall be delivered at the expense of the Manufacturer to the address provided by the user of the warranty or to the medical store where it was purchased. If the repaired product is not collected by the warranty user, he shall be obliged to bear all related costs incurred by LIW Care Technology Sp. z o.o., including the costs of storage and transport of the product.
14. The warranty granted by LIW Care Technology Sp. z o.o. for the product does not affect the rights of the buyer arising from the warranty for defects in the sold item.

NOTE!

PLEASE KEEP THE WARRANTY CARD IN A SAFE PLACE.

LIW Care Technology Sp. z o.o. requires this document to be submitted before accepting a warranty repair.

Name of the device/model:

Serial number:

Date of sale:

Stamp and signature of the seller:

o.	Date of repair notification	Description of operations	Date of repair completion	Stamp and signature of the person performing the repair